

ΩMEGA

RETAINING WALL SYSTEM

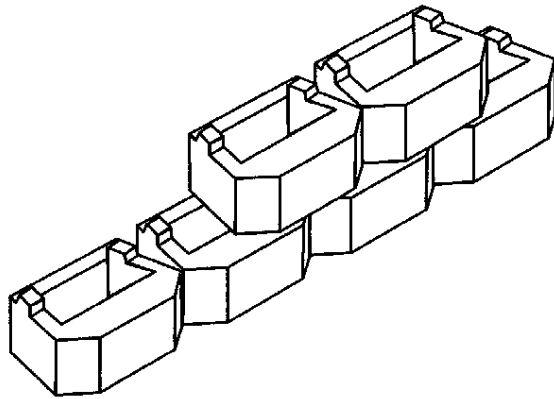

Technical Installation Information



THE PHILLIPS COMPANIES
www.thephillipscompanies.com

Omega™ Retaining Wall Specification

1. General

1.1 Description

- A. This work shall consist of furnishing and installing an Omega™ Segmental Retaining Wall System in accordance with these specifications and in reasonably close conformity to the lines, grades, and dimensions shown on the plans.
- B. Construction drawings and design calculations for the segmental retaining wall system shall be prepared and sealed by a registered professional engineer. The contractor shall submit the construction drawings and design calculations to the engineer for approval prior to beginning construction.

1.2 Certification

- A. The contractor shall submit a Manufacturer's certification prior to the start of construction that the segmental retaining wall system components meet the requirements of this specification.
 - 1. The contractor's submittal package shall include but not be limited to actual test results for the creep, durability, construction damage, pullout, and geogrid – block connection strength.
- B. The design of the segmental retaining wall system shall be in accordance with NCMA Design Guidelines For Segmental Retaining Walls, 1993.

2. Products

2.01 Definitions

- A. Geogrid – A structural element formed by a rectangular network of integrally connected tensile members with apertures of sufficient size to allow interlocking with surrounding soil.
- B. Modular Facing Unit – A man made concrete unit manufactured on a block machine.
- C. Unit Fill – Granular aggregate material placed in the open areas of the modular facing units.
- D. Reinforced Backfill – Compacted soil that is placed within the reinforced zone as shown on the plans.

- E. Retained Backfill – That area immediately behind the reinforced backfill.

2.02 Modular Facing Units

- A. Modular facing units shall conform to the following architectural requirements:

Color – Standard manufacturers’ color or custom color as specified by the Owner.

Finish – Angular three-sided configuration with sculptured rock face.

Joints – The modular facing units shall be stacked in a running bond configuration such that there is no continuous vertical joint.

- B. Modular facing units shall conform to the following material requirements:

- 1. Cement – Materials shall conform to the following applicable specifications.

- a. Portland Cement – ASTM C 150

- b. Modified Portland Cement – Portland cement conforming to ASTM C 150, modified as follows. Limestone – calcium carbonate, with a minimum 85% content, may be added to the cement, provided these requirements of C 150 as modified are met:

- (1) Limitation on insoluble residue 1.5%

- (2) Limitation on air content of mortar – volume percent, maximum 22%

- (3) Limitations of loss of ignition 7%.

- c. Blended Cements – ASTM C 618

- d. Pozzolans – ASTM C 618

- e. Fly Ash – ASTM C 331

- 2. Aggregates – Aggregates shall conform to the following specifications, as applicable.

- a. Normal Weight Aggregates – ASTM C 33

- b. Lightweight Aggregates – ASTM C 331

- 3. Other Components – Air entraining agents, coloring pigments, integral water repellents, finely ground silica, and other additives shall be previously established as suitable for use in segmental retaining wall system modular facing units and shall conform to applicable ASTM standards.

- C. Modular facing units shall conform to the following structural and geometric requirements:

Compressive strength = 3000 psi

Adsorption = 8% maximum (6% in northern states) for standard weight aggregates

Maximum horizontal gap between crected units shall be ½”

Vertical setback = 1” per course

2.3 Leveling Pad Material

- A. Material shall consist of a compacted crushed stone base or non-reinforced concrete as shown on the construction drawings. The leveling pad shall be 6” thick. As an option, concrete may be 3” thick with 3” of compacted granular base for a total thickness of 6”.

2.4 Unit Fill

- A. Unit fill shall consist of clean 1” minus crushed stone or crushed gravel meeting the gradation:

<u>Sieve Size</u>	<u>Percent Passing</u>
1 inch	100
¾ inch	75 – 100
No. 4	0 – 10
No. 50	0 – 5

- B. One cubic foot of unit fill shall be used for each square foot of wall face. Unit fill shall be placed within the cores of, between, and behind the units to meet this requirement.

2.5 Reinforced Backfill

- A. Reinforced Backfill shall be free from debris and meet the following gradation requirements:

<u>Sieve Size</u>	<u>Percent Passing</u>
2 inch	100 – 75
¾ inch	100 – 75
No. 4	100 – 20
No. 40	0 – 60
No. 200	0 – 25

Plasticity Index (PI) < 10

Liquid Limit < 40

- B. The maximum aggregate size shall be limited to ¾ inch unless field tests have been performed to evaluate potential strength reductions to the geogrid design due to damage during construction.
- C. Material can be on site materials where the above requirements can be met. Unsuitable soils for backfill (high plastic clays or organic soils) shall not be used in the reinforced zone.
- D. The contractor shall submit soils samples and laboratory test results to the Engineer for approval prior to the start of construction.

2.06 Geosynthetic Reinforcements

- A. Geosynthetic Reinforcements shall consist of high tenacity geogrids or geotextiles manufactured for soil reinforcement applications. The type strength and placement location of the reinforcing geosynthetic shall be as shown on the plans. The design properties of the reinforcement shall be determined according to the procedures outlined in this specification and the NCMA Design Manual for Segmental Retaining Walls (1996 Revision). Detailed test data shall be submitted to the Owner’s Engineer for approval at least 30 days prior to construction.

This data shall be generated from a comprehensive manufacturing quality assurance/quality control (MQA/MQC) program where sampling of the material for testing is as set forth by ASTM D 4354-96 (Standard Practice for Sampling of Geosynthetics for Testing). Tested properties included are tensile strength (ASTM D 4595 & GRI:GG1), creep (ASTM D 5262-95, wherein testing has been conducted for a minimum of 10,000 hours), installation damage [Installation Damage Test developed by Watts and Brady (1994) of the Transportation Research Laboratory in the United Kingdom or GRI:GG4), durability [GRI:GG4(a) for stiff geogrids, GRI:GG4(b) for flexible geogrids (to also include GRI:GG7 & GRI:GG8 for polyester), pullout (GRI:GG5 or GRI:GT6), and connection (NCMA SRWU-1).

Included with the raw test data shall be a certification that the proposed geosynthetic reinforcement(s) have the following MARV (minimum average roll value) properties:

Property	Geosynthetic Type		
	Type 1	Type 2	Type 3
Allowable Tensile Strength, T _a			
Coefficient of Interaction, C _i			
Coefficient of Direct Sliding, C _{DS}			

Calculation of the allowable reinforcement tension shall use the following method:

Allowable Tensile Strength:

The allowable tensile strength, T_a , at the end of the service life shall consider the time-temperature creep characteristics of the reinforcement, environmental degradation, construction-induced damage, and an overall factor of safety.

$$T_a = \frac{LTDS}{FS_{UNC}} = \frac{T_{ult}}{RF_D \cdot RF_{ID} \cdot RF_{CR} \cdot FS_{UNC}}$$

where:

T_{ult} = Ultimate (or yield tensile) strength from wide width tensile strength tests (ASTM D 4595 or GRI “GG1: Single Rib Geogrid Tensile Strength”), based on MARVs for the product.

RF_D = Durability reduction factor. It is dependent on the susceptibility of the geosynthetic to attack by microorganisms, chemicals, thermal oxidation, hydrolysis and stress cracking. The typical range is from 1.1 to 2.0.

RF_{ID} = Installation damage reduction factor. It can range from 1.05 to 3.0 depending on backfill gradation and product mass per unit weight.

RF_{CR} = Creep reduction factor. It is the ratio of the ultimate strength (T_{ult}) to the creep limit strength obtained from laboratory creep tests for each product, and can vary typically from 1.5 to 5.0.

FS_{UNC} = Overall factor of safety or load reduction factor to account for uncertainties in the geometry of the structure, fill properties, reinforcement properties, and externally applied loads. The typical value is 1.5.

In no case shall the product $RF_{ID} \times RF_D \times RF_{CR}$ be less than 2.0.

3. Construction

3.01 Excavation

- A. The contractor shall excavate to the lines and grades shown on the plans. Care shall be taken to insure that the base material is completely compacted, proof rolling it prior to placing the facing units.

3.02 Leveling Pad

- A. The leveling pad shall be placed to the lines and grades shown on the plans.
- B. Where concrete leveling pads are required they shall be to the size shown on the plans.
- C. Where granular leveling pads are required they shall be compacted to 95% standard or 90% modified Proctor, and shall be to the size shown on the plans.

3.03 Modular Facing Unit Installation

- A. The first course of units shall be placed on the leveling pad. The alignment and level shall be checked and adjusted as necessary.
- B. Position the next course of units so that their sidewalls fit into the void between the alignment lip of the units below them.
- C. Maximum stacked vertical height of the facing units shall not exceed two units prior to filling the cores of the units with the granular material as well as placing the select backfill.
- D. Whole or cut units in curves or corners shall be placed with the running bond centered on the units below them.
- E. Top units shall be secured to the units below them with an adhesive recommended by the manufacturer.

3.04 Geogrid Installation

- A. The geogrid shall be oriented so that the highest strength axis is placed perpendicular to the wall face.
- B. The geogrid shall be placed at the elevations and to the length shown on the plans.
- C. The geogrid shall be placed horizontally on the compacted fill. The next course of facing units shall be placed on top of the geogrid to secure it prior to pulling the geogrid taut and anchoring it in place. The next lift of backfill shall then be placed over the geogrid.
- D. The geogrid shall be continuous for the entire embedment length shown on the plans. Spliced reinforcement is not allowed.

3.05 Backfill Placement

- A. Backfill placement shall be placed, spread, and compacted generally away from the wall face in a manner that will minimize developing slack in the geogrid.
- B. Backfill shall be placed and compacted in lifts not greater than 10 inches.
- C. Backfill shall be compacted to 95% of the maximum density as determined by ASTM D695. The moisture content of the backfill prior to and during compaction shall be uniform in each lift.
- D. Only lightweight hand operated compaction equipment shall be allowed within 3 feet of the back of the facing units.

- E. Tracked construction equipment shall not be allowed directly upon the geogrid. A minimum of six inches of backfill shall be placed prior to operation of tracked equipment upon the geogrid. Turning of the tracked vehicles shall be kept to minimum to prevent displacing the backfill and/or damaging the geogrid.
- F. Rubber tired equipment may be operated directly upon the geogrid at slow speeds. Sudden braking and/or sharp turning shall not be allowed.
- G. At the end of each day's operation the contractor shall slope the last lift of backfill away from the facing units so that runoff will not cause damage to the wall structure. The contractor shall make sure that runoff from adjacent areas does not enter the backfill area of the wall.

4. Measurement and Payment

- A. The retaining wall shall be paid for by square foot area of the wall. The area of wall shall be from the top of the leveling pad to the highest facing unit. The unit price for the wall shall be the unit price bid of the contract.